

**planting notes:**

- PLANTS ARE TO BE PLACED IN THE CENTRE OF THE HOLES
- PLANTS TO BE PLACED SO AS TO MATCH CROWN OF THE PLANTS WITH SURROUNDING SURFACE LEVEL
- AFTER REMOVAL FROM CONTACTER THE HANDLING OF THE ROOT SYSTEMS MUST BE DONE WITH A MINIMUM OF DISTURBANCE
- PLANTS MUST BE HEALTHY AND PLANT ROOT SYSTEMS MUST BE MOIST AT THE TIME OF PLANTING. PLANTS MUST BE WATERED IN WITH APPROX. 10 LITRES OF WATER AT TIME OF PLANTING.

**general notes**

- GARDEN BEDS TO BE 125MM (MIN) TOP SOIL (APPROVED) Laid ON PREPARED SUBGRADE. APPLY 2kg GYPSUM OR APPROVED SIMILAR MATERIAL PER SQUARE METRE AND THOROUGHLY MIX WITH EXISTING SITE SOIL.
- ALL GARDEN BEDS TO HAVE ADEQUATE DRAINAGE AND BE FREE DRAINING AT ALL TIMES.
- MULCH (50MM DEPTH MIN.) TO BE FINE PINE WOOD TO APPROVAL. MULCH IS TO MATCH LEVELS OF SURROUNDING FINISHED SURFACES.
- TIMBER EDGE BOARD TO BE 100x25MM TREATED PINE OR APPROVED.

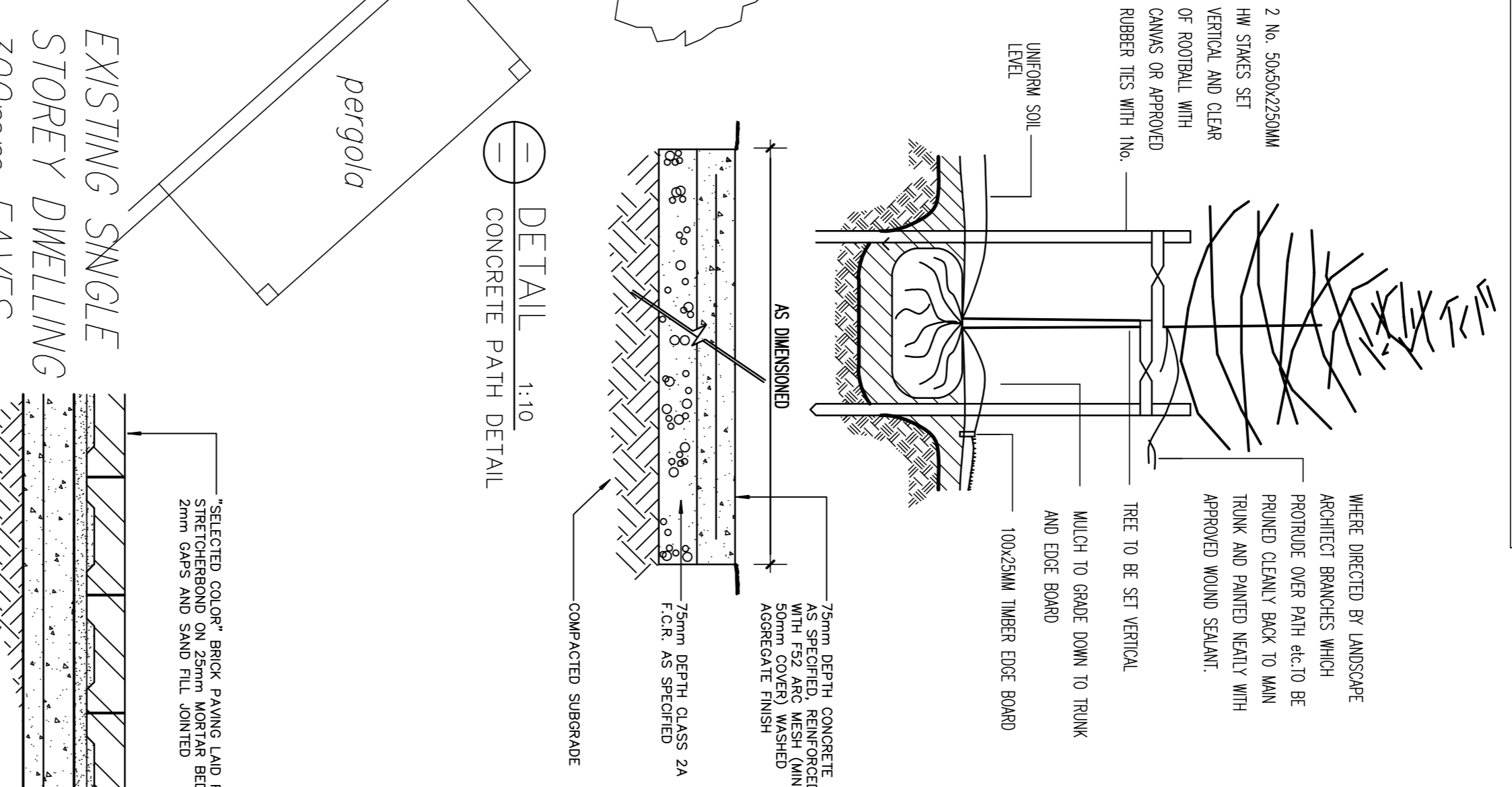

**LANDSCAPE SCHEDULE**

SYMBOL	BOTANICAL NAME	COMMON NAME	MATURE SIZE	INSTALLED SIZE	INSTALLED HEIGHT	QUANTITY
Es	EUCALYPTUS SCOPARIA PRUNUS CAULEPANA CHANTICLEER SHRUBS & CLIMBERS	WALLANGARA WHITE GUM CHANTICLEER ORNAMENTAL PEAR	12.0m x 8.0m 6.0m x 6.0m	35LIT 45LIT	2000mm 2000mm	2
A.G.S	ADONIA SMITHII "GREEN SCREEN" CORREA ALBA CALLISTEMON "LITTLE JOHN"	GREEN SCREEN LILLY PILLY WHITE CORREA DWARF CALLISTEMON	2.5m x 1.2m (HEAD) 1.2m x 1.5m 1.0m x 1.0m	300mm 200mm 200mm	700mm 200mm 200mm	18 15
Ca	DIETES BICOLOR DANIELLA REVOLUTA ECHIUM FASTIOSUM	SPANISH IRIS FLAX LILY PRIDE OF MADERA	1.0m x 1.0m 1.0m x 0.8m	150mm 150mm 200mm	150mm 150mm 200mm	5 7
Dr	EUPHORBIA CHARACAS "WULFENIT" GREVILLEA ROYAL WANDLE	SPURGE ROYAL WANDLE GREVILLEA	1.5m x 1.5m	150mm	250mm	2
E.C.W	HEBE HARTMANA LOMADRA LONGIFOLIA STRELITZIA REGINAE	PURPLE VERONICA MATT RUSH BIRDS OF PARADISE	1.0m x 1.0m 1.0m x 1.0m 1.5m x 1.0m	150mm 150mm 200mm	150mm 150mm 400mm	3
R.R.W	WESTRINGIA WINNABAE	WINNABAE GERR	1.2m x 1.5m	200mm	400mm	
Li						
Sr						
W.W.G						
TOTAL						52

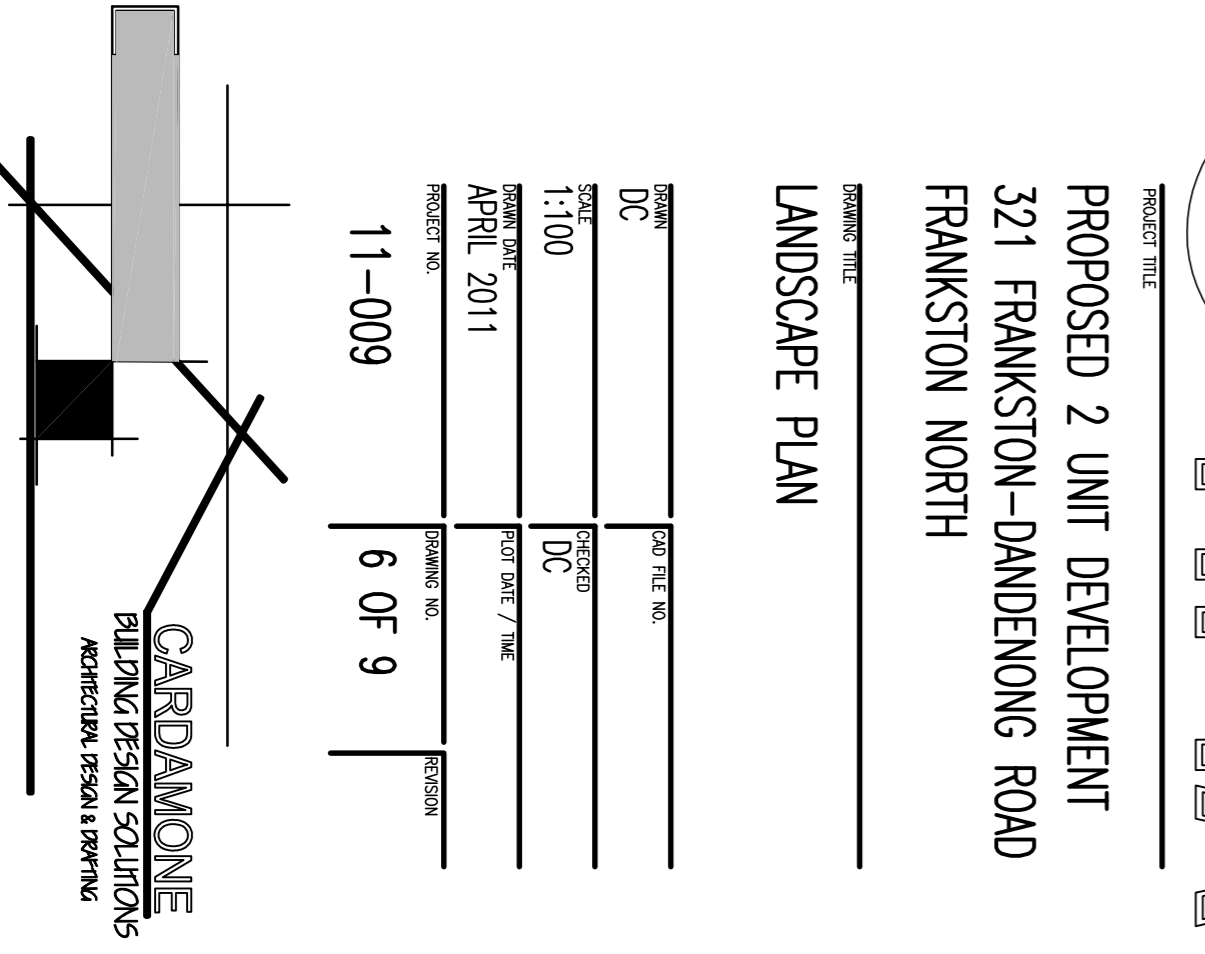
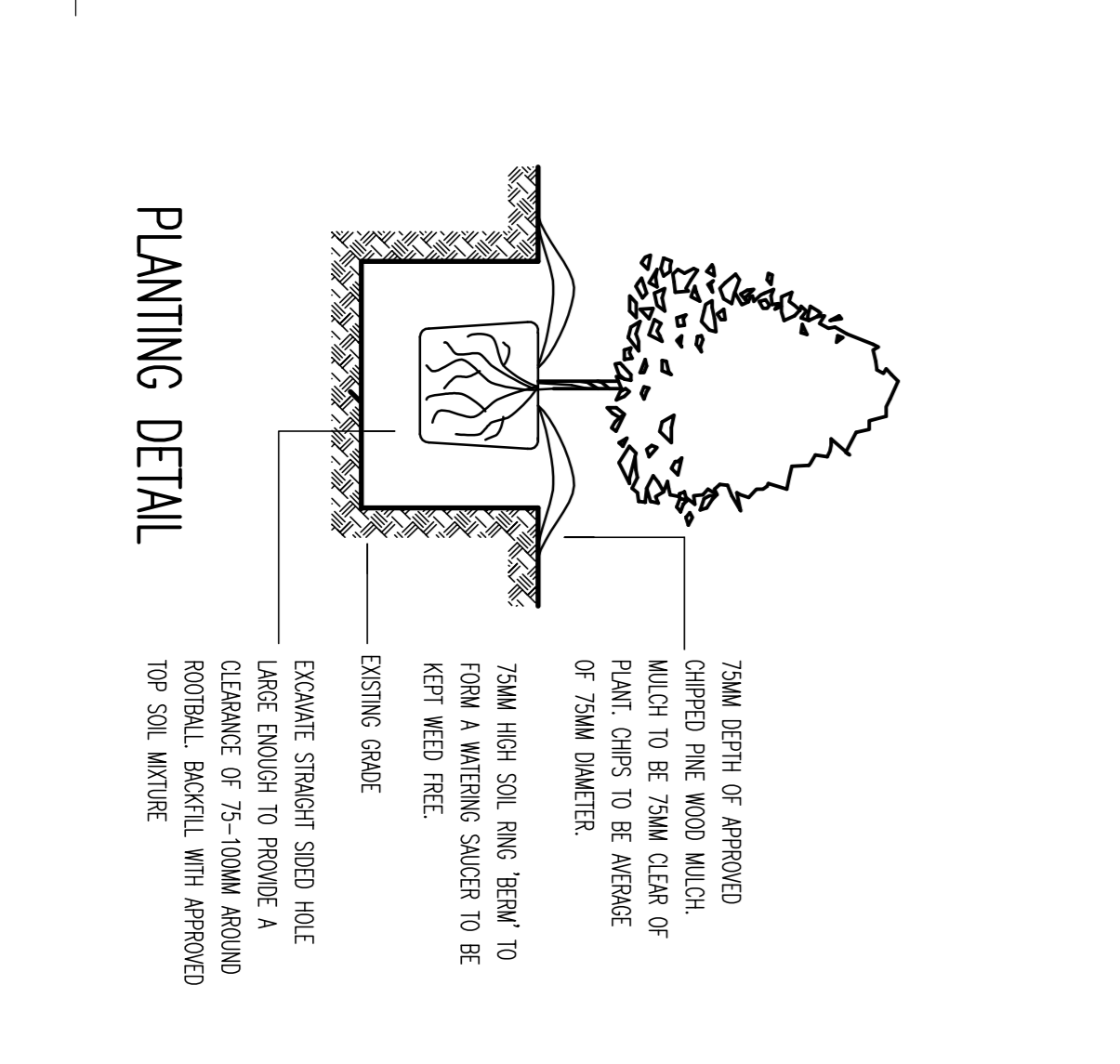
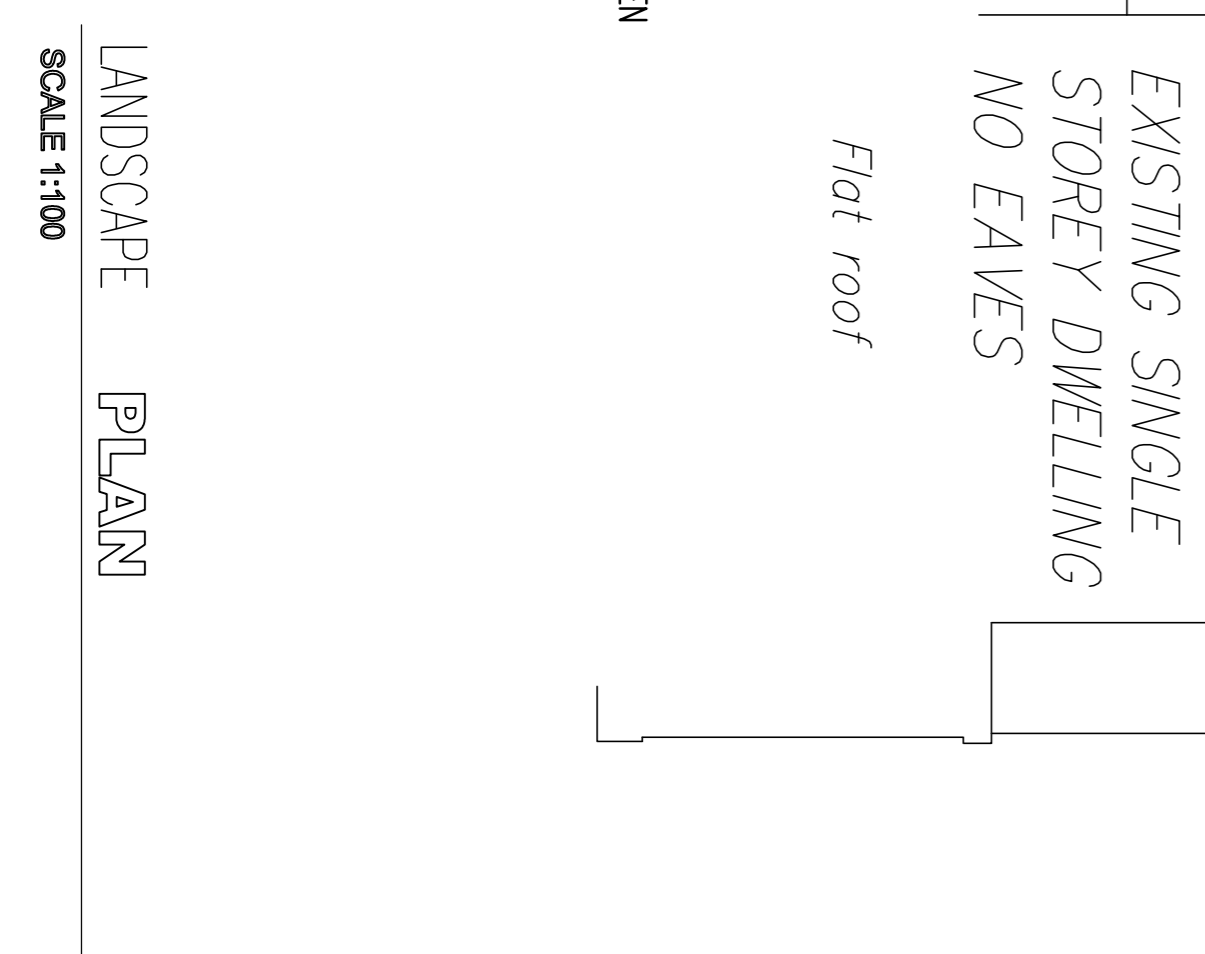
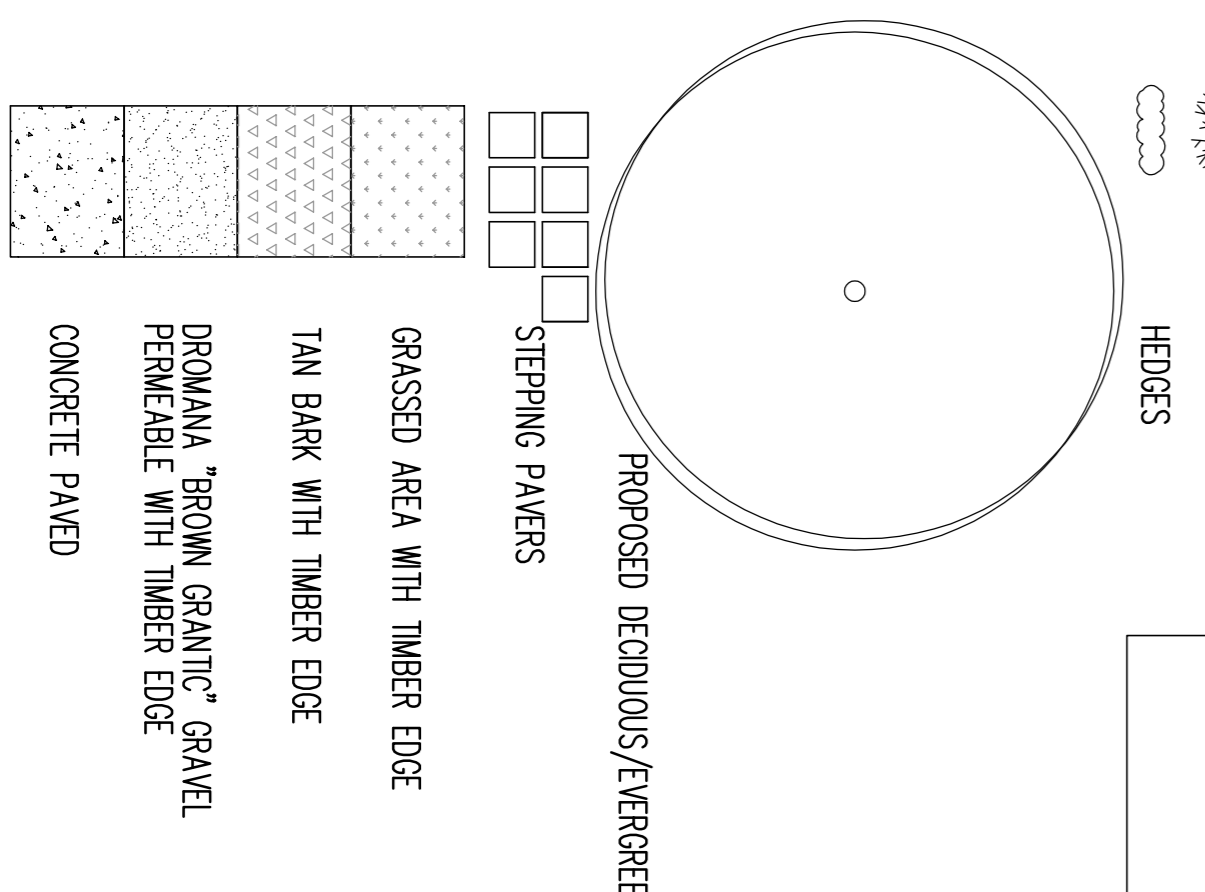
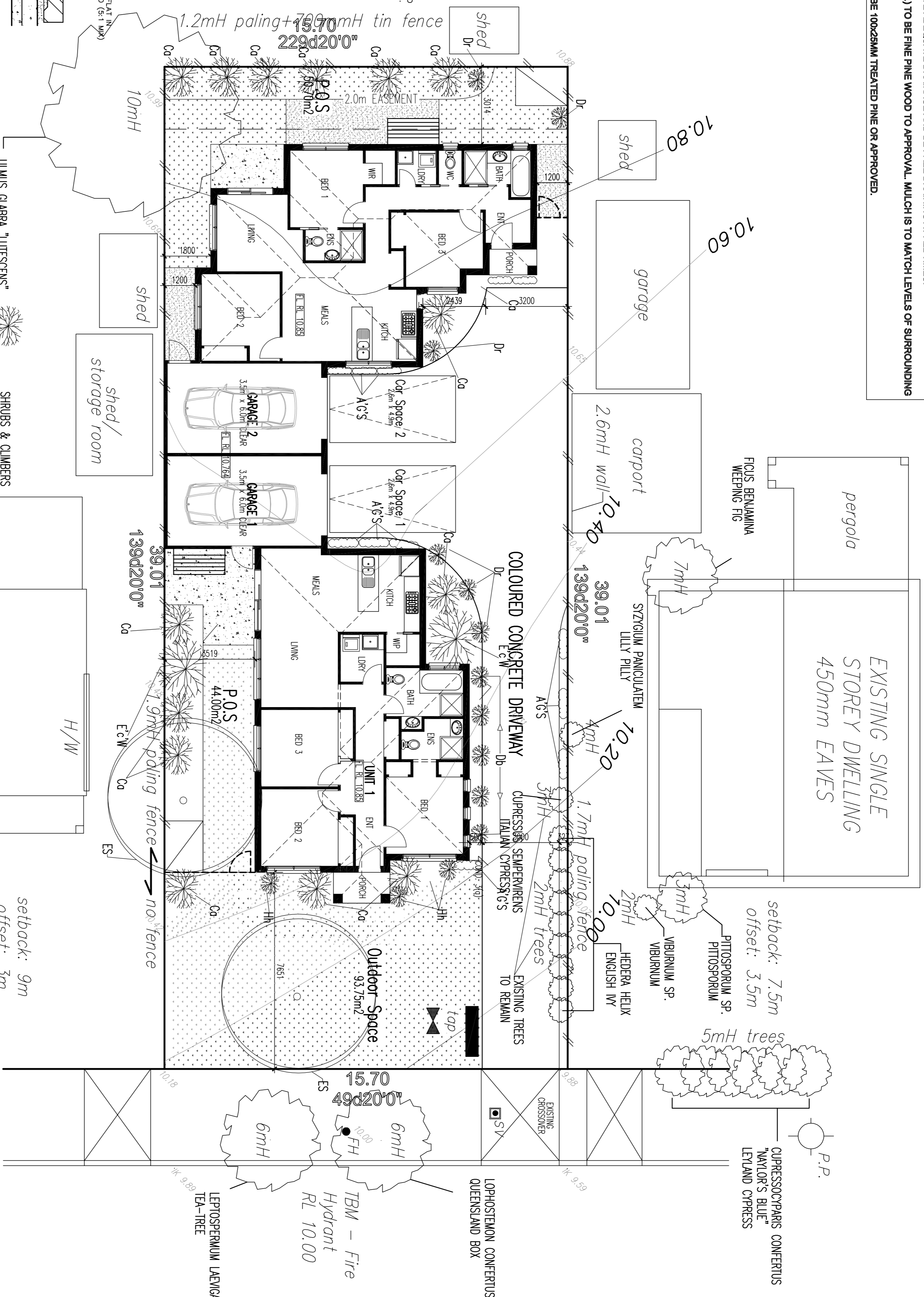

**AREA ANALYSIS**

UNIT	GR. FLOOR	PORCH	GARAGE	TOTAL
UNIT 1	97.85	2.64	23.14	121.87
UNIT 2	90.26	1.85	23.14	115.25
TOTAL	188.11	4.49	46.28	238.88

**TOTAL BUILT UP AREA** 237.12

**TOTAL SITE AREA** 612.9m

**SITE COVERAGE** 38.75%

**DRIVEWAY** 140.00m<sup>2</sup>

**PERMEABLE SURFACE** 38.38%

THIS DRAWING IS THE COPYRIGHT OF CARDAMONE BUILDING DESIGN SOLUTIONS AND IS NOT TO BE REPRODUCED WITHOUT WRITTEN APPROVAL. DIMENSIONS TAKE PRECEDENCE OVER SCALE. IF IN DOUBT ASK.

**CARDAMONE BUILDING DESIGN SOLUTIONS**  
ARCHITECTURAL DESIGN SERVICES

**PROPOSED 2 UNIT DEVELOPMENT**  
321 FRANKSTON-DANDENONG ROAD  
FRANKSTON NORTH

**LANDSCAPE PLAN**

DATE: DC  
SCALE: 1:100  
DATE: APRIL 2011  
PROJECT NO: 11-009

DATE: DC  
SCALE: 1:100  
DATE: APRIL 2011  
PROJECT NO: 6 OF 9